

Introduction to x86 systems

M. Sonza Reorda

Politecnico di Torino
Dipartimento di Automatica e Informatica

1

M. Sonza Reorda – a.a. 2005/06

Origins of PC

The first Personal Computer (PC) was sold by IBM in 1981.

Its main characteristics were:

- 16-bit microprocessor (8088)
- 4.7 MHz frequency
- 64 Kb RAM
- Drivers for diskette (360 Kb) and cassette recorder (optional)
- Black and white monitor.

2

M. Sonza Reorda – a.a. 2005/06

General architecture

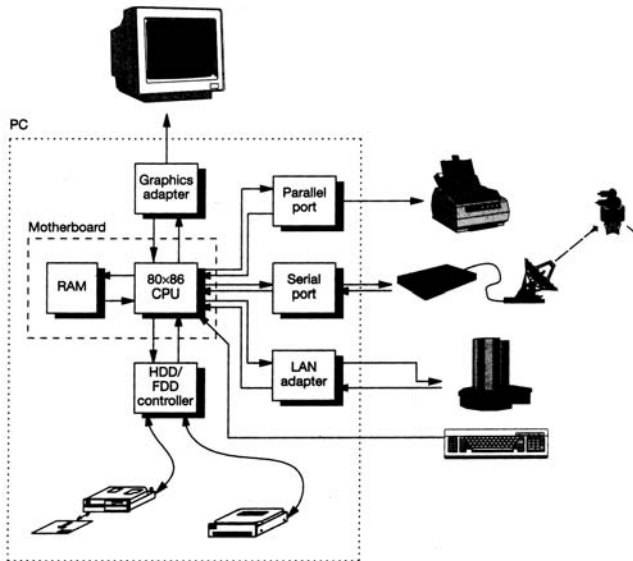

3

teorda – a.a. 2005/06

8086

- Introduced in 1978 as the successor of 8-bit 8080
- Composed of about 29,000 transistors
- 16-bit architecture
- 123 instructions (including those for string manipulation)
- Special features:
 - Multiplexed data/address bus
 - Two operating modes (maximum and minimum).

4

M. Sonza Reorda – a.a. 2005/06

DIP
(Dual In-line
Package)

Pins and signals

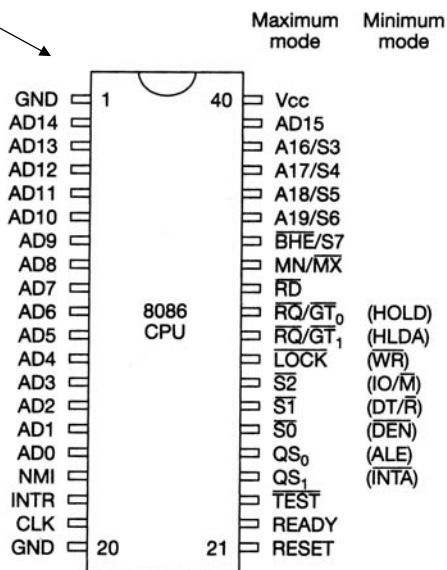

5

nza Reorda – a.a. 2005/06

Minimum and maximum mode

The operating mode is selected by the value on a given pin (MN/MX):

- In *minimum mode*, the 8086 directly generates the necessary control signals for the bus
- In *maximum mode*:
 - The processor only outputs status signals to the bus controller, which generates the bus control signals
 - The maximum mode configuration allows supporting more complex systems, where bus signals must be driven with sufficient power
 - Using MULTIBUS, several processors can be combined in a single system.

6

M. Sonza Reorda – a.a. 2005/06

Real mode

Each time memory has to be accessed, two 16-bit values are combined, and a 20-bit address is generated.

Memory access

The 8086 has a multiplexed data and address bus.
Read and write bus cycles are 4-clock cycles long.
Additional clock cycles can be dynamically added if required, based on the value of the READY signal.

Word boundaries

The 8086 can access to the memory in several ways:

- Accessing to single bytes or to words, if the address is even
- Accessing to bytes, if it is odd.

The BHE signal is used to manage the data transfer size.

8088

It is very similar to 8086, but its data bus is 8-bit wide.

When accessing to even-addressed words, the 8088 requires 2 bus cycles instead of one.

Therefore, it is slower than the 8086.

80186/80188

They are mainly *microcontrollers* derived from the 8086/8088.

The instruction set is larger and a bit more optimized, so that the speed is about 25% higher.

They were seldom used in PCs, but they were relatively popular for special-purpose systems.

80286

- First released in 1982
- Composed of about 134,000 transistors
- 16-bit microprocessor
- Supports the *protected virtual address mode*
- 24-bit address bus
- 16-bit data bus
- w.r.t. 8086:
 - Higher working frequency (up to 25 MHz)
 - Fewer clock cycles to execute an instruction
 - Optimized memory access.
- Big commercial success (more than 15 million sold).

Pinout

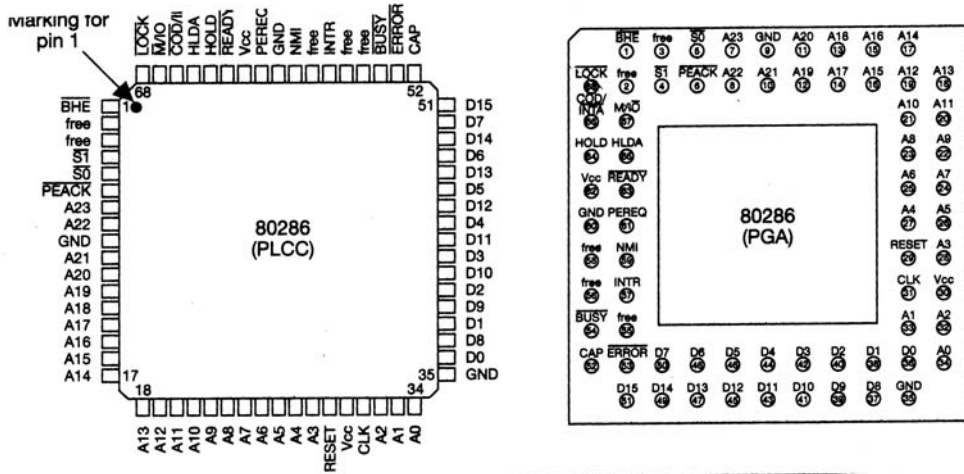

13

M. Sonza Reorda – a.a. 2005/06

Layout

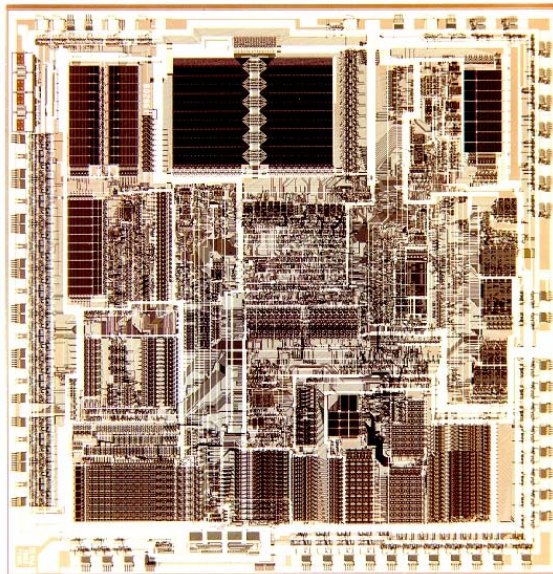

14

M. Sonza Reorda – a.a. 2005/06